



ATMO Summit

PRAGUE

25-26/11/2024





New *R744* Integral Plant in Migros Bellinzona Nord



#GoNatRefs

99'175 employees

Sales of CHF 32.0 billion

Migros at a glance

With sales of **CHF 32.0 billion (2023)**, the Migros Group is the largest retail company in Switzerland and employs more than 97,700 people, making it the largest private employer in Switzerland.

Migros founded in 1925, is owned by more than **2.32 million cooperative members** who are organised into ten regional cooperatives. These cooperatives run the core business of the Migros Group – **the retail business** – with 639 branch stores.

Ambitious climate targets, products with transparent sustainability ratings and an increased commitment to combating food waste: Migros has achieved a great deal in all strategic areas in 2023.



- | | |
|----------------------|----------------------------|
| 1 Aare | 8 Vaud |
| 2 Basilea | 9 Vallese |
| 3 Ginevra | 10 Zurigo |
| 4 Lucerna | A CD MVN - NNF/Congelati |
| 5 Neuchâtel-Friburgo | B CD MVS - Coloniali |
| 6 Ostschweiz | C CD MVV - Vestiti/Tessili |
| 7 Ticino | |

Founded in 1933

52 stores

Migros Ticino at a glance

In 1933 was founded **the first Cooperative, Migros Ticino**, a local company that has always been interested in the economic, social and cultural development of the region in which it operates.

Migros Ticino is a dynamic and versatile Cooperative that operates in several areas of activity. Areas that include food and non-food commerce with the 34 supermarkets, 3 outlets and 8 specialized stores, foodservice with 7 facilities including restaurants and take-aways, 7 wineshops “Vinarte”, the promotion of fitness and wellness with 6 centers “Activ Fitness Ticino” and the publication of the weekly magazine “Azione”.

Another key factor in Migros Ticino's corporate philosophy is sustainability: the Cooperative relies heavily on new technologies to increase the efficiency of its branches. The company works daily to **reduce its environmental impact** by plant optimization, by installing photovoltaic panels on their buildings, by transporting merchandise on rail and by purchasing electric vehicles to reduce CO₂ emissions.

Migros Energy and Environmental Goals 2030



In this framework Migros and consequently also Migros Ticino Cooperative set concrete goals, which were split between stores and the Logistics Headquarters located in S. Antonino



The goals were originally quantified in 2004 and subsequently updated in 2019. They are verified annually in collaboration with the **Energy Agency for the Economy (AEnEc)**

1

Reduction of greenhouse gas emissions by at least 42% compared to 2020.
The percentage is expected to be around 76.7% for Migros Ticino with its planned projects

2

Reduction of energy purchase by 10% compared to 2020.
For Migros Ticino, the reduction will be around 15.6 %, as a result of planned projects

CO₂ integral TotalGreEnergy plants

Continuous desire to test new technologies while seeking the most effective tools to achieve its sustainability goals, as of 2016, Migros Ticino has been producing both industrial cold and heat for heating with the same plants: **TotalGreEnergy** was born! Designed, manufactured and installed by the company **E. Biaggini SA**, in collaboration with **Eliwell by Schneider Electric**. Over the past few years, Migros Ticino has mostly invested in CO₂ combined plants. By the end of 2024, there will be 13 combined plants, 19 commercial refrigeration-only and 2 conventional plants.

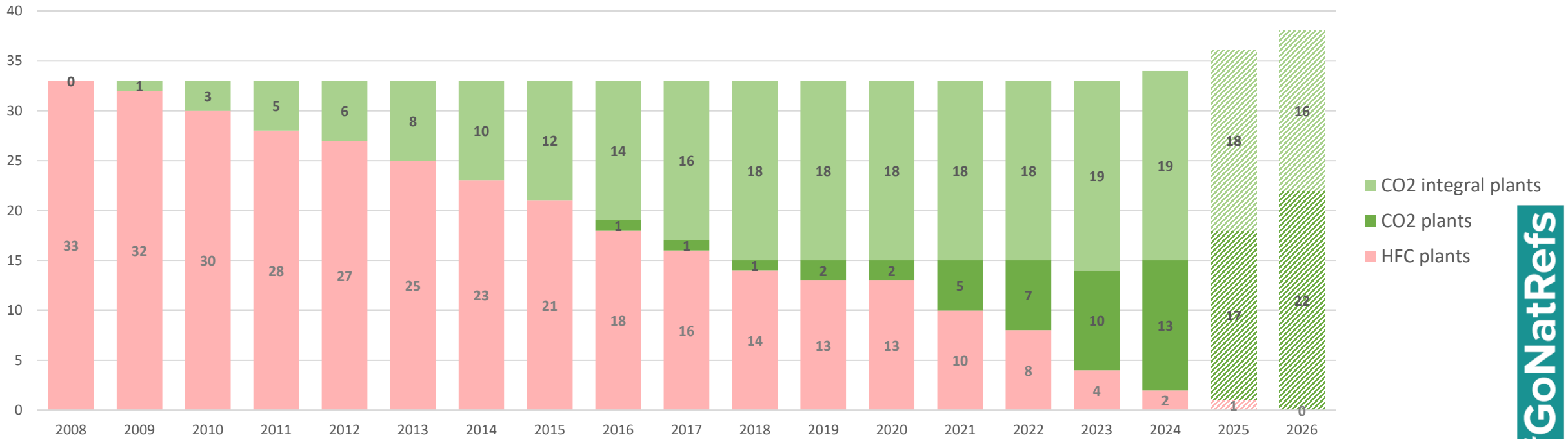

25-26/11/2024 - Prague

Comparison of refrigeration plants consumption

- Using closed refrigerated furniture, thermodynamic characteristics of *R744*, and continuous development of this technology have ensured the drastic decrease in energy consumption, quantified by the **KWZ** parameter (kWh/ml*year)
- From 2009 to 2018, the electrical consumption of CO₂ plants has been reduced by **1'000 kWh/ml*y**
- From 2018 to 2024, the electrical consumption of CO₂ plants has been reduced by **500 kWh/ml*y** thanks to **TotalGreEnergy** installations

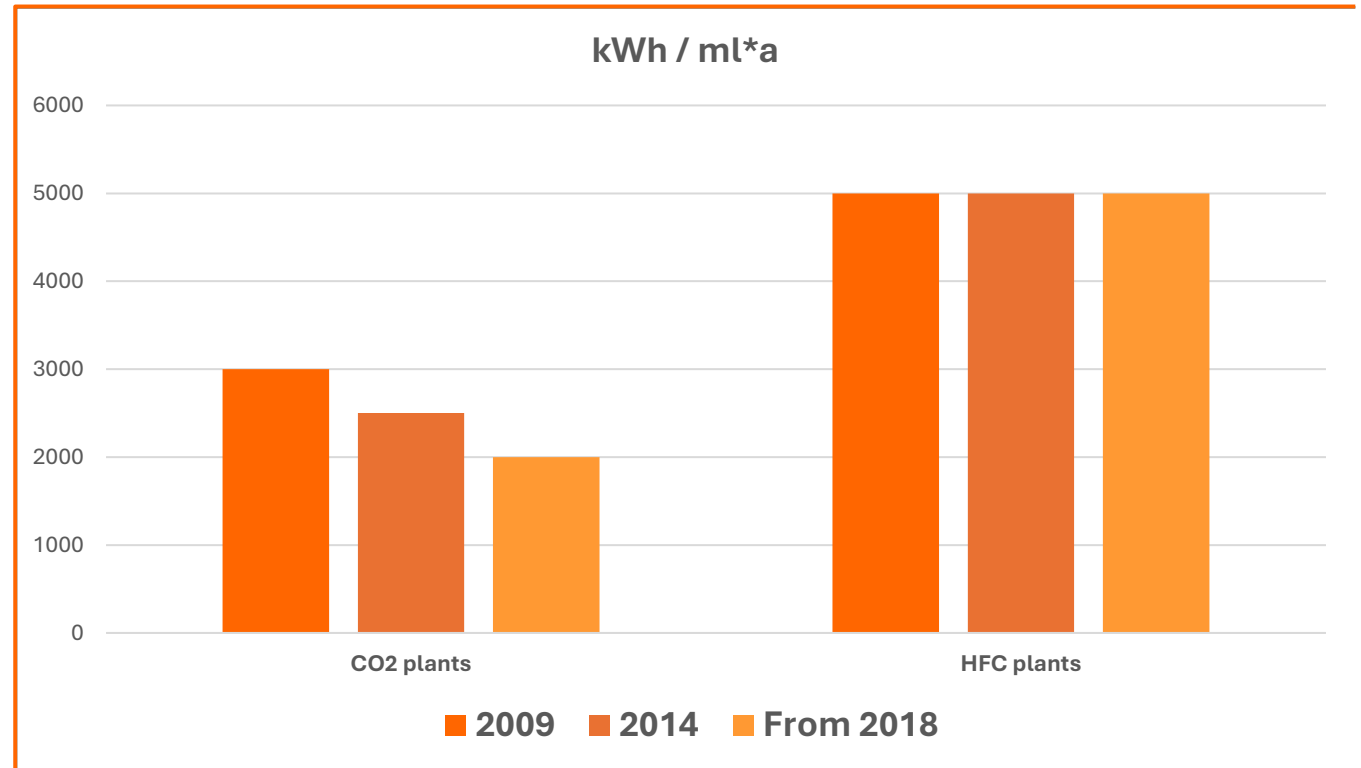

MM Bellinzona Nord opening June 2024

- Area 800 m²
- Fully integrated **R744** system for **HVACR** requirements
- 1'274 Photovoltaic panels (roof and facades)
 - **352 kWp**
 - about **300 MWh/year**
 - self-sufficient
- Power stations for electric cars
- Supply by electric-powered truck



25-26/11/2024 - Prague



ATMO Summit

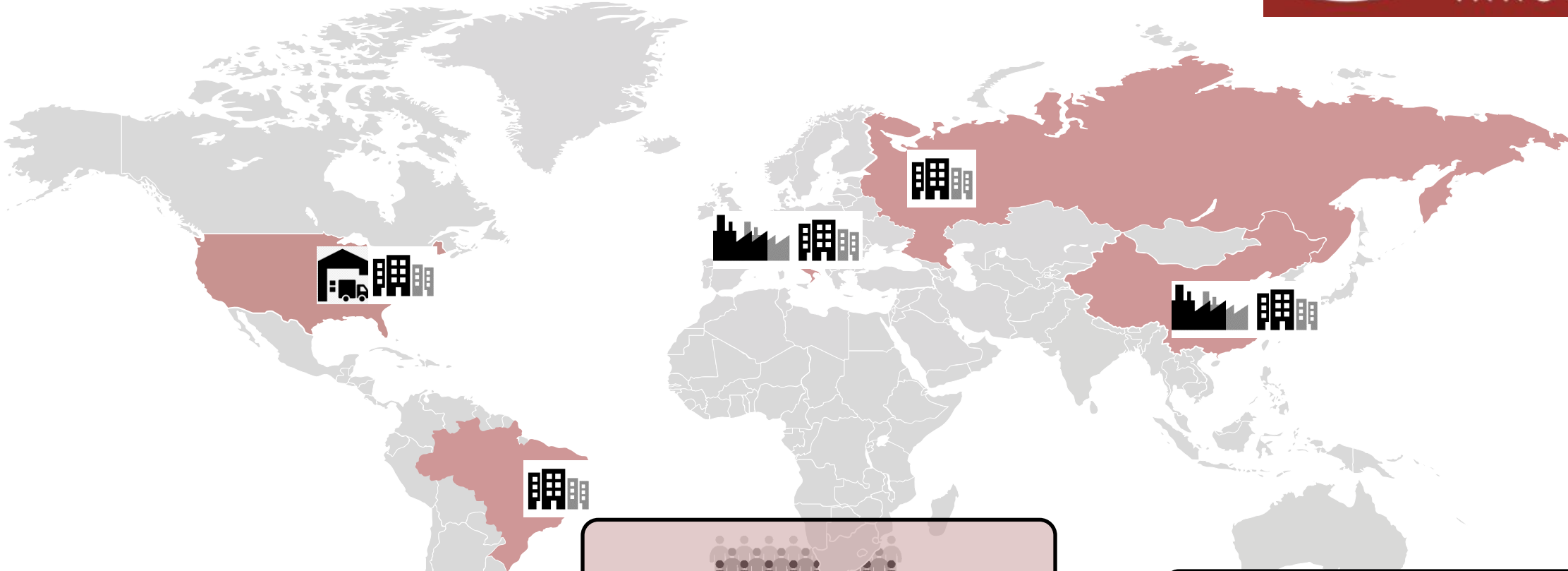

HQ in FLORENCE
ITALY



200 EMPLOYEES
4 PRODUCTION SITES
5 SALES OFFICES



75.000+ COMPRESSORS
(2022)

25-26/11/2024 - Prague

#GoNatRefs

LSPM MOTORS

- CD PRO+ Feature **LSPM** Electric Motors - **L**ine **S**tart **P**ermanent **M**agnets
- Hybrid Synchronous Motor Obtained By Implementing Permanent Magnets Into The Rotor
- No Need To Be Inverter Driven (Line Start)
 - Special Rotor Aluminum Cage That Allows Self Starting
 - Starts As A Standard Squirrel Cage Asynchronous Motor
 - Then Switches To Synchronous Operation

PERFORMANCE IMPROVEMENTS

- Consistent, Almost Flat Mass Flow Increase
- Noticeable Power Consumption Decrease
- **COP Increase Up To 13%**
 - HIGHER Rpm's
 - Less Electric Losses

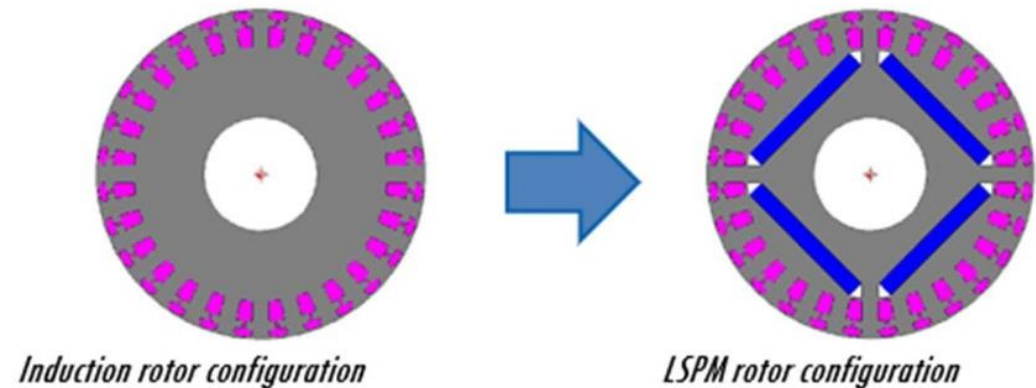

CD3000H STANDARD

LSPM MOTORS

Input

Model	CD 3000H
Refrigerant	R744_CO2
Operating mode	Transcritical
Evaporating temperature	-10.0 °C
Gas cooler pressure	90.0 bar
Superheat	10.0 K
Evap. outlet superheat	10.0 K
Gas cooler outlet temperature	35.0 °C
Voltage / phases / frequency	380-420 V / 3

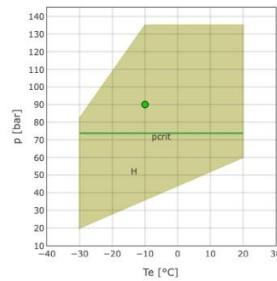

H = Standard application
 - = Critical pressure 73,77 bar
 • = Dew temperature

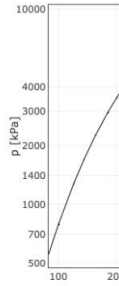

Performance calculation

	At evaporator	At compressor
Cooling capacity	38000 W	38000 W
Absorbed power	21.02 kW	21.02 kW
Gas cooler capacity	59.01 kW	59.01 kW
COP	1.81	1.81
Mass flow	911.6 kg/h	911.6 kg/h

CD3000H PRO+

Input

Model	CD 3000H PRO+
Refrigerant	R744_CO2
Operating mode	Transcritical
Evaporating temperature	-10.0 °C
Gas cooler pressure	90.0 bar
Superheat	10.0 K
Evap. outlet superheat	10.0 K
Gas cooler outlet temperature	35.0 °C
Voltage / phases / frequency	380-420 V / 3 / 50

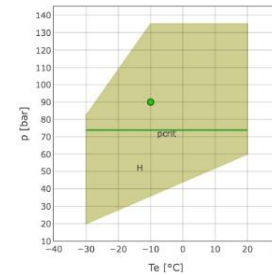

H = Standard application
 - = Critical pressure 73,77 bar
 • = Dew temperature

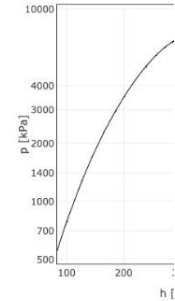

Performance calculation

	At evaporator	At compressor
Cooling capacity	40770 W	40770 W
Absorbed power	20.83 kW	20.83 kW
Gas cooler capacity	61.59 kW	61.59 kW
COP	1.96	1.96
Mass flow	978.1 kg/h	978.1 kg/h



Compressor rack specs.

MT Compressors	[pcs.]	3 pcs. Dorin CD4 75-6.6M PRO+
LT Compressors	[pcs.]	3 pcs. Dorin CDS 151B
Aux Compressors	[pcs.]	2 pcs. Dorin CD4 120-9.5H PRO+
MT capacity (To = -4°C)	[kW]	50
LT Capacity (To = -28°C)	[kW]	18
Heating water ΔT	[°C]	+35 -> +45
Cooling water ΔT	[°C]	+15 -> +10
Ground Water ΔT	[K]	6
Chiller Capacity	[kW]	110
Heat Pump Capacity	[kW]	90
Chiller EER	[-]	6.90
Heat Pump COP	[-]	4.50
MT Stage EER	[-]	4.40
LT Stage EER	[-]	5.20
Global EER	[-]	5.50
Electronic controller	[-]	Eliwell EWCM 9000 PRO



ATMO Summit

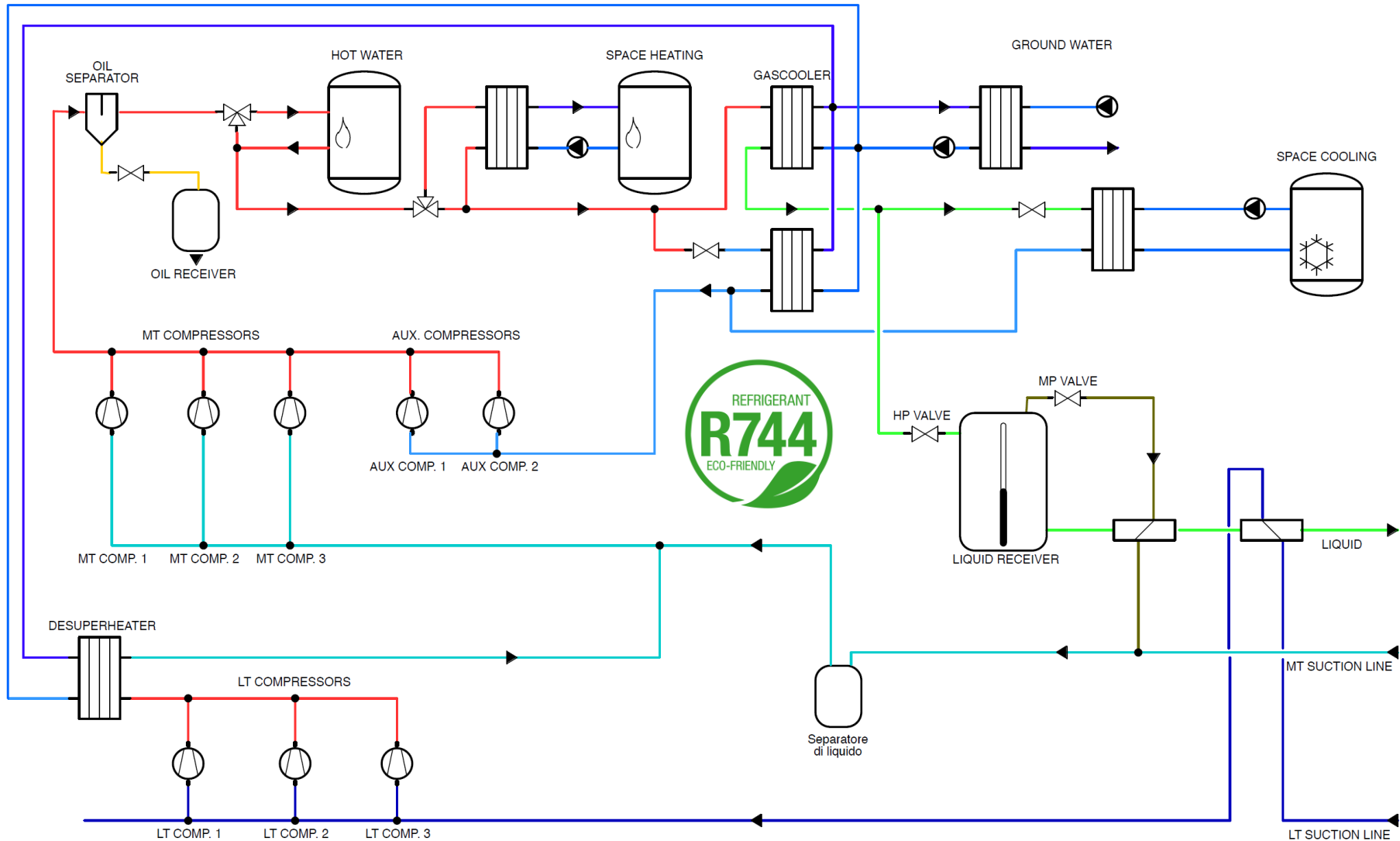

25-26/11/2024 - Prague

#GoNatRefs

How well is it working? HP mode Energy Balance

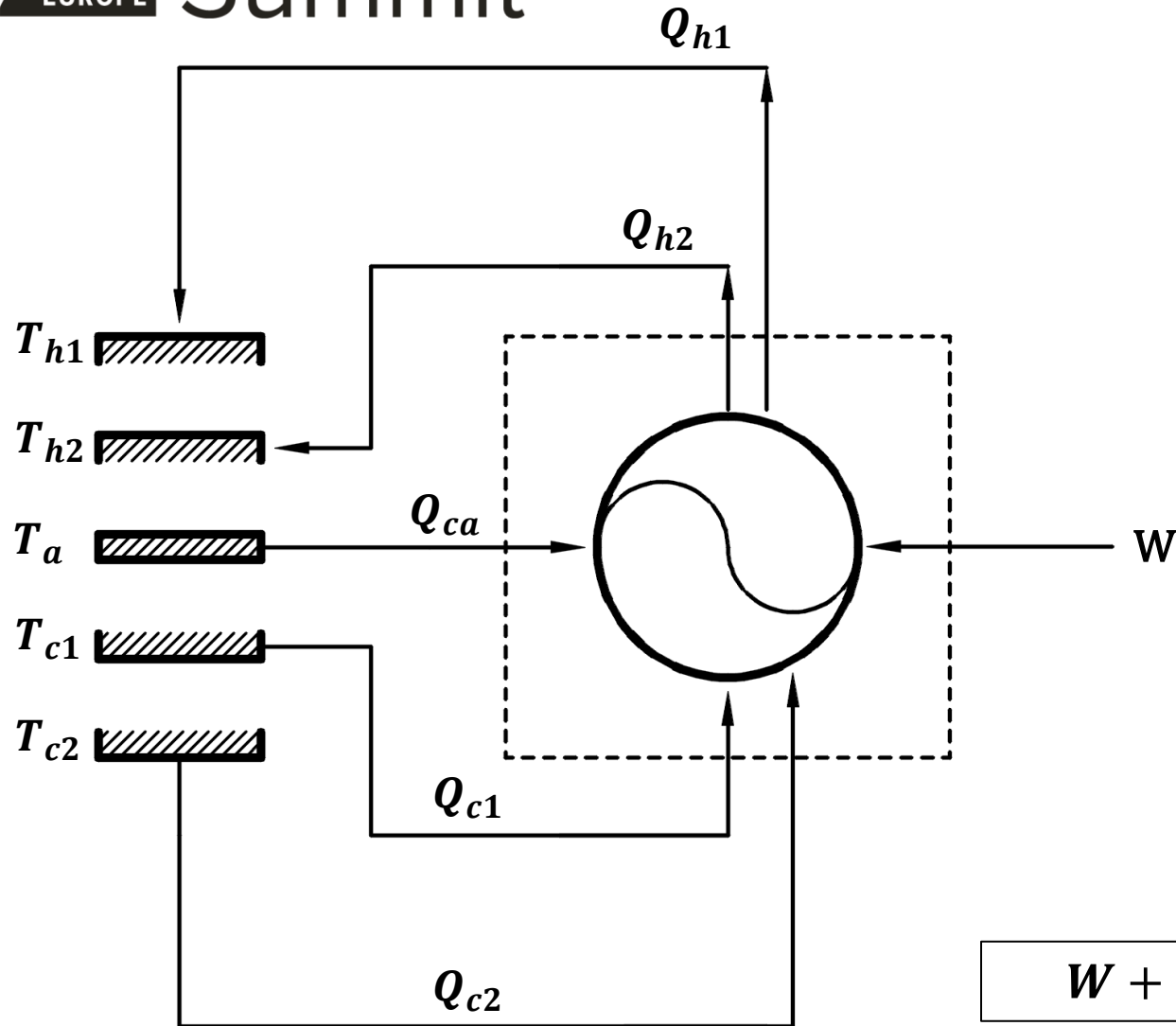

- Q_{h1} = Hot water [kW]
- Q_{h2} = Space heating [kW]
- Q_{ca} = From the ground [kW]
- Q_{c1} = MT Q_o [kW]
- Q_{c2} = LT Q_o [kW]
- W = Electrical power [kW]
- T_{h1} = Hot water T° [K]
- T_{h2} = Space heating T° [K]
- T_a = Ground water T° [K]
- T_{c1} = MT utilities T° [K]
- T_{c2} = LT utilities T° [K]

$$W + Q_{c1} + Q_{c2} + Q_{ca} = Q_{h1} + Q_{h2}$$



How well is it working? HP mode Exergy Balance

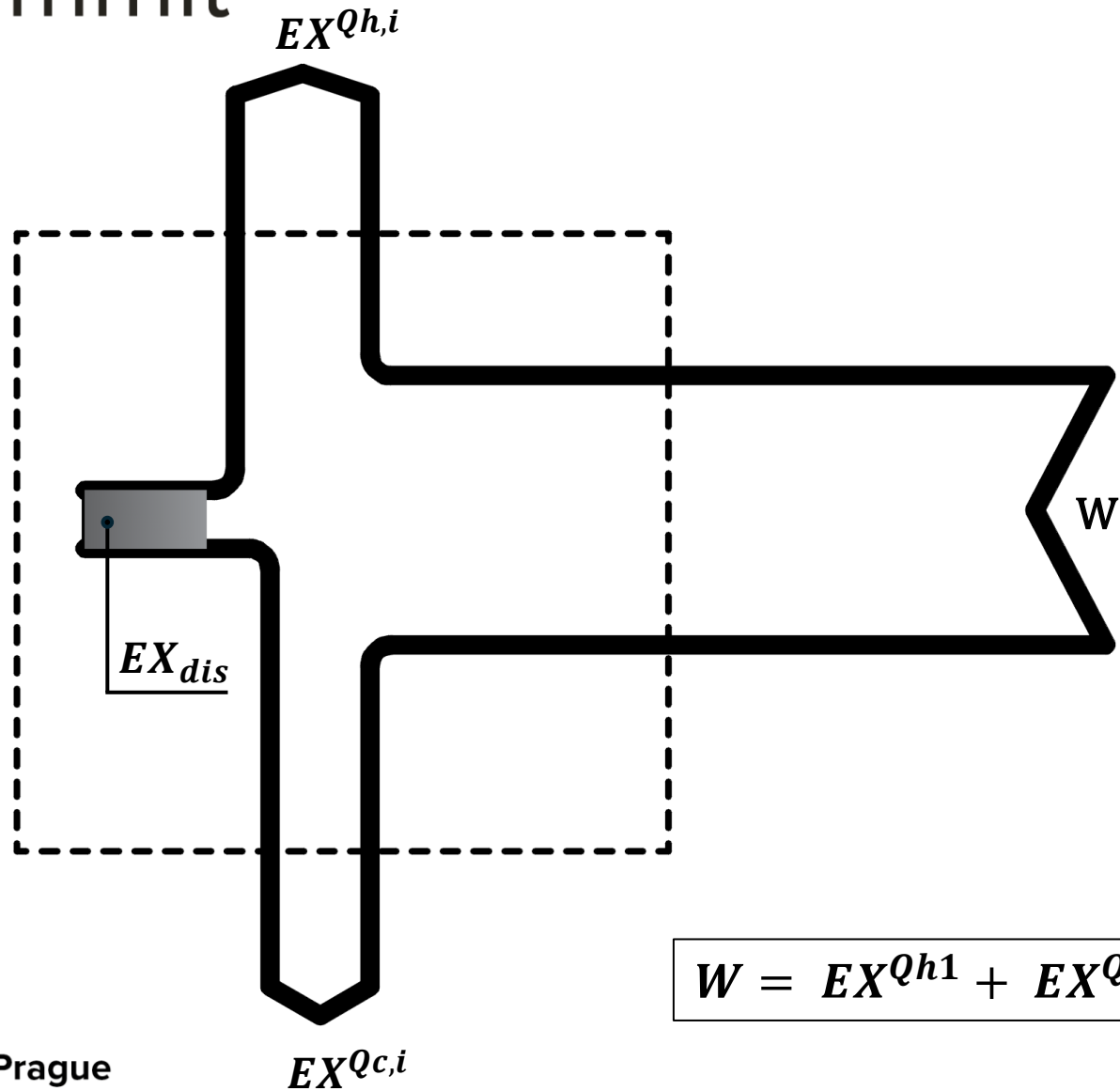

$$\left\{ \begin{array}{l} EX^{Qh,1} = Q_{h1} \cdot \left(1 - \frac{T_a}{T_{h1}}\right) > 0 \\ EX^{Qh,2} = Q_{h2} \cdot \left(1 - \frac{T_a}{T_{h2}}\right) > 0 \\ EX^{Qc,1} = Q_{c1} \cdot \left(1 - \frac{T_a}{T_{c1}}\right) < 0 \\ EX^{Qc,2} = Q_{c2} \cdot \left(1 - \frac{T_a}{T_{c2}}\right) < 0 \\ EX^{Qa} = Q_a \cdot \left(1 - \frac{T_a}{T_a}\right) = 0 \\ EX_{dis} = T_a \cdot S_{gen} \\ S_{gen} > 0 \end{array} \right.$$

$$W = EX^{Qh1} + EX^{Qh2} - EX^{Qc1} - EX^{Qc2} + EX_{dis}$$

How well is it working? HP mode Exergy efficiency

$$\eta_{ex} = \frac{COP_{real}}{COP_{ideal}} = \frac{Q_{h1} \cdot \left(1 - \frac{T_a}{T_{h1}}\right) + Q_{h2} \cdot \left(1 - \frac{T_a}{T_{h2}}\right) - Q_{c1} \cdot \left(1 - \frac{T_a}{T_{c1}}\right) - Q_{c2} \cdot \left(1 - \frac{T_a}{T_{c2}}\right)}{W}$$

- $Q_{h1} = 25 \text{ kW}$
- $Q_{h2} = 160 \text{ kW}^*$
- $Q_{c1} = 50 \text{ kW}$
- $Q_{c2} = 18 \text{ kW}$
- $W = 47 \text{ kW}$
- $T_{h1} = 333 \text{ K}$
- $T_{h2} = 318 \text{ K}$
- $T_a = 283 \text{ K}$
- $T_{C1} = 275 \text{ K}$
- $T_{C2} = 253 \text{ K}$

 $\eta_{ex} = 53\%$

* (Heat pump + free heating recovery)

**Energy data:
June 2024 - November 2024**

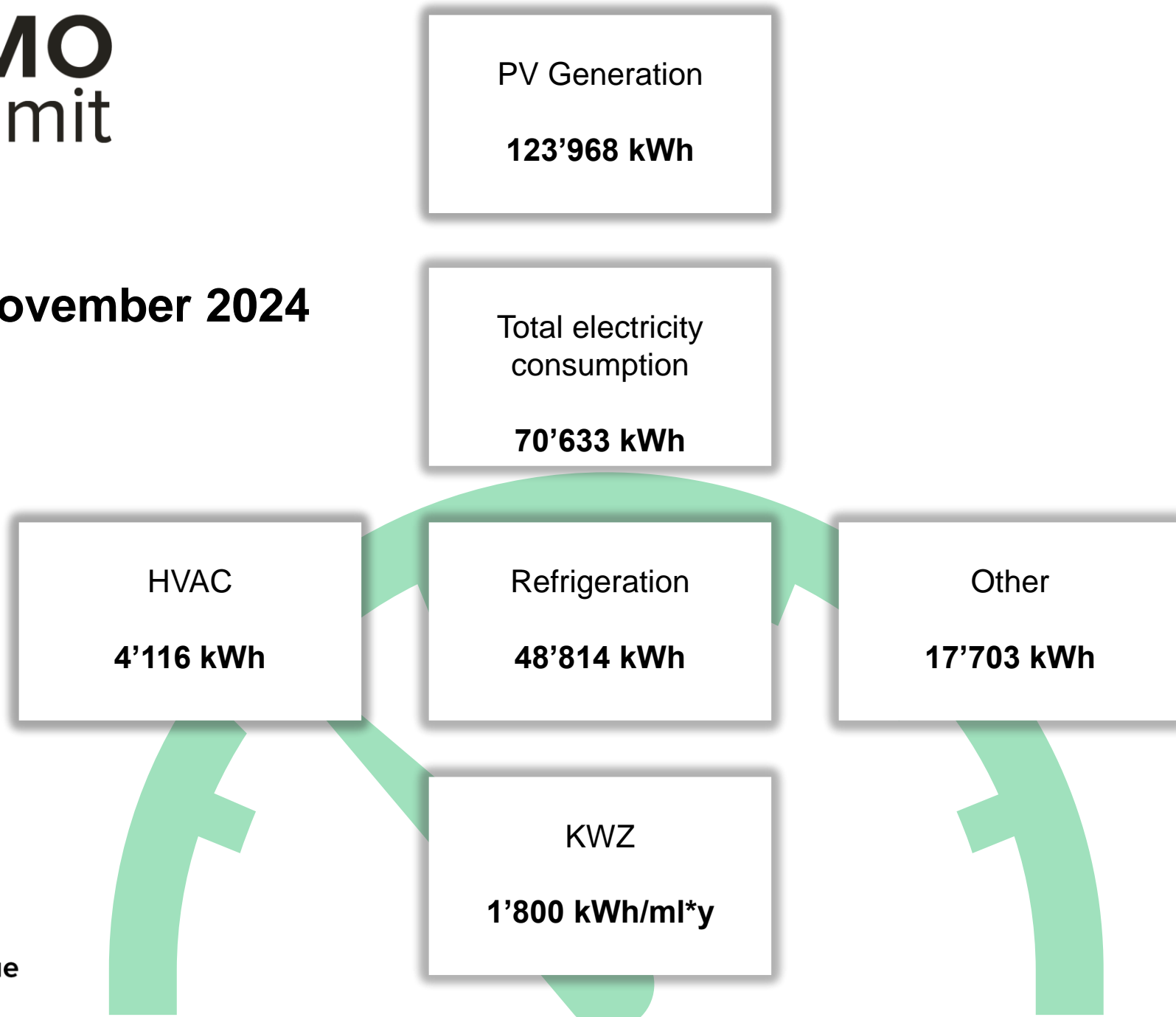

PV GENERATION

- Refrigeration
- HVAC
- Other
- To grid

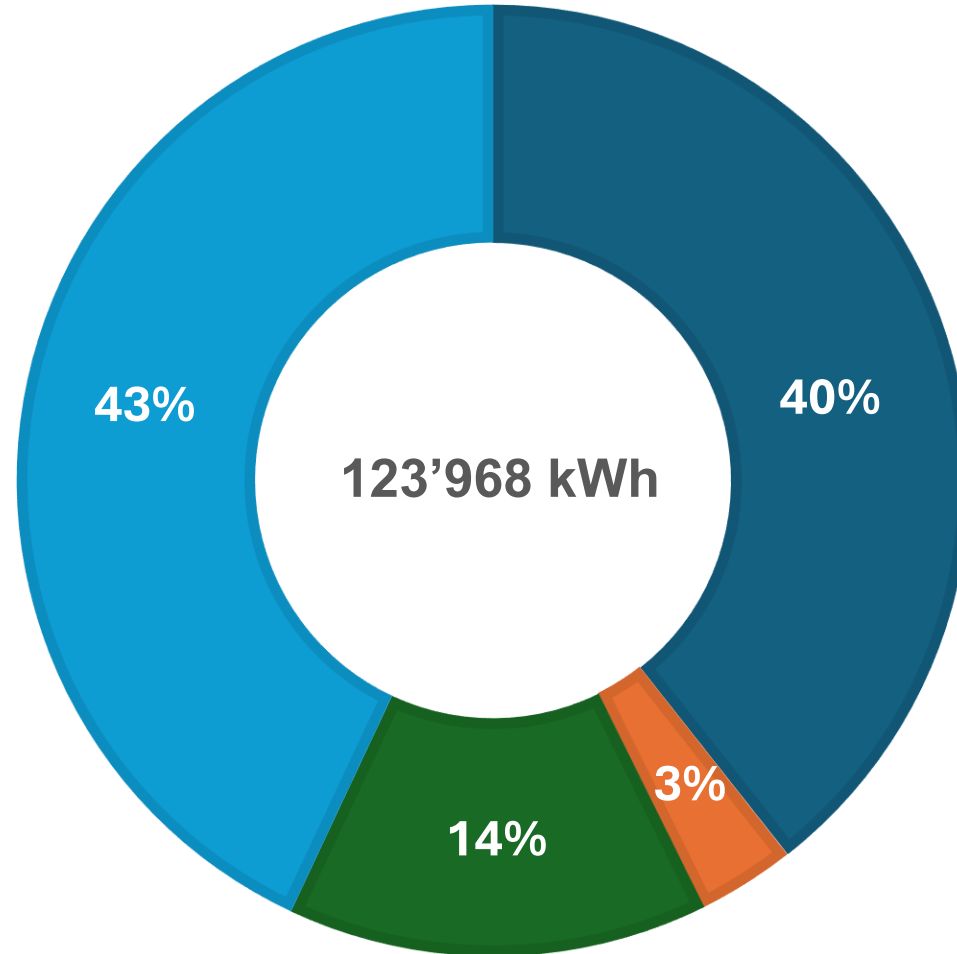

53'335 kWh have been provided to the Swiss grid!



MINERGIE[®]
Better building. Better living.



Feedbacks and savings

- New **R744** plant has been running in Migros Bellinzona Nord since 4 months
- **KWZ = 1'800 kWh/ml* year** (better than benchmark value: 2'000 kWh/ml* year)
- High performing heating recovery thanks to **TotalGreEnergy** layout
- **R744** Integrated plant for all energy requirements
- Ground water pumps 0-10V managed directly by TotalGreEnergy plant
- Global **GWP = 1**
- **PV** production higher than electricity needs: renewable solar energy put into grid
- **Investment cost ≈ 25% lower** than traditional plants with burner/heat pump + air conditioning systems
- Migros Bellinzona building store is **HFC free** and 100% **CO₂ friendly**

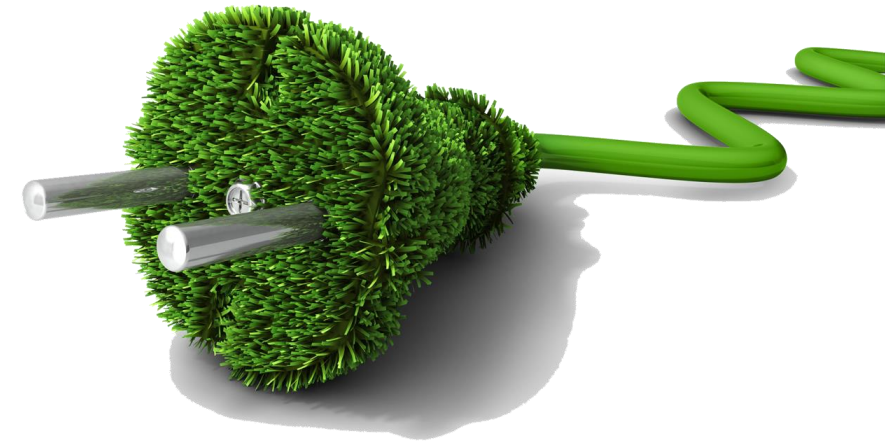

Future plans Migros - Biaggini

- Reducing greenhouse in Migros stores by 2030
- Reducing energy purchasing by 2030
- 100% CO₂ installations by 2025
- 0% HFC running installations by 2025
- **TotalGreEnergy** are new standard for all Migros stores
- Extending **R744** technology in HVAC and industry as well
- Improving **energy efficiency** and **KWZ** in existing and new installations



Swiss Made
TotalGreEnergy



ATMO
Summit

PRAGUE

25-26/11/2024

THANK YOU
for listening!

